

STUDIO PROFESSIONALE DI INGEGNERIA
Ing. Danilo MASSA

Via Tristani 15 - 09127 Cagliari - tel. 3493889667 - e-mail ing.danilomassa@gmail.com



COMUNITA' MONTANA
SARCIDANO - BARBAGIA DI SEULO

PROGETTO DEFINITIVO-ESECUTIVO

**INTERVENTO DI MANUTENZIONE STRAORDINARIA
E MESSA IN SICUREZZA DELLA PISTA CICLABILE
ISILI-NURAGUS - PROGETTO PILOTA "MACIMED"**

TAVOLE DI PROGETTO

OGGETTO:

**PARTICOLARE COSTRUTTIVO BARRIERE
SEZIONI TIPO TRATTI CON PARTICOLARI**

ELABORATO:

TAV. 3

SCALA:

1:20

DATA:

marzo 2014

AGGIORNAMENTO:

IL PROFESSIONISTA:

Ing. Danilo Massa

VISTI:

PARTICOLARE BARRIERA SCALA 1:20

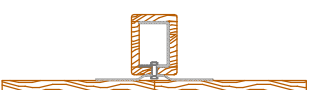
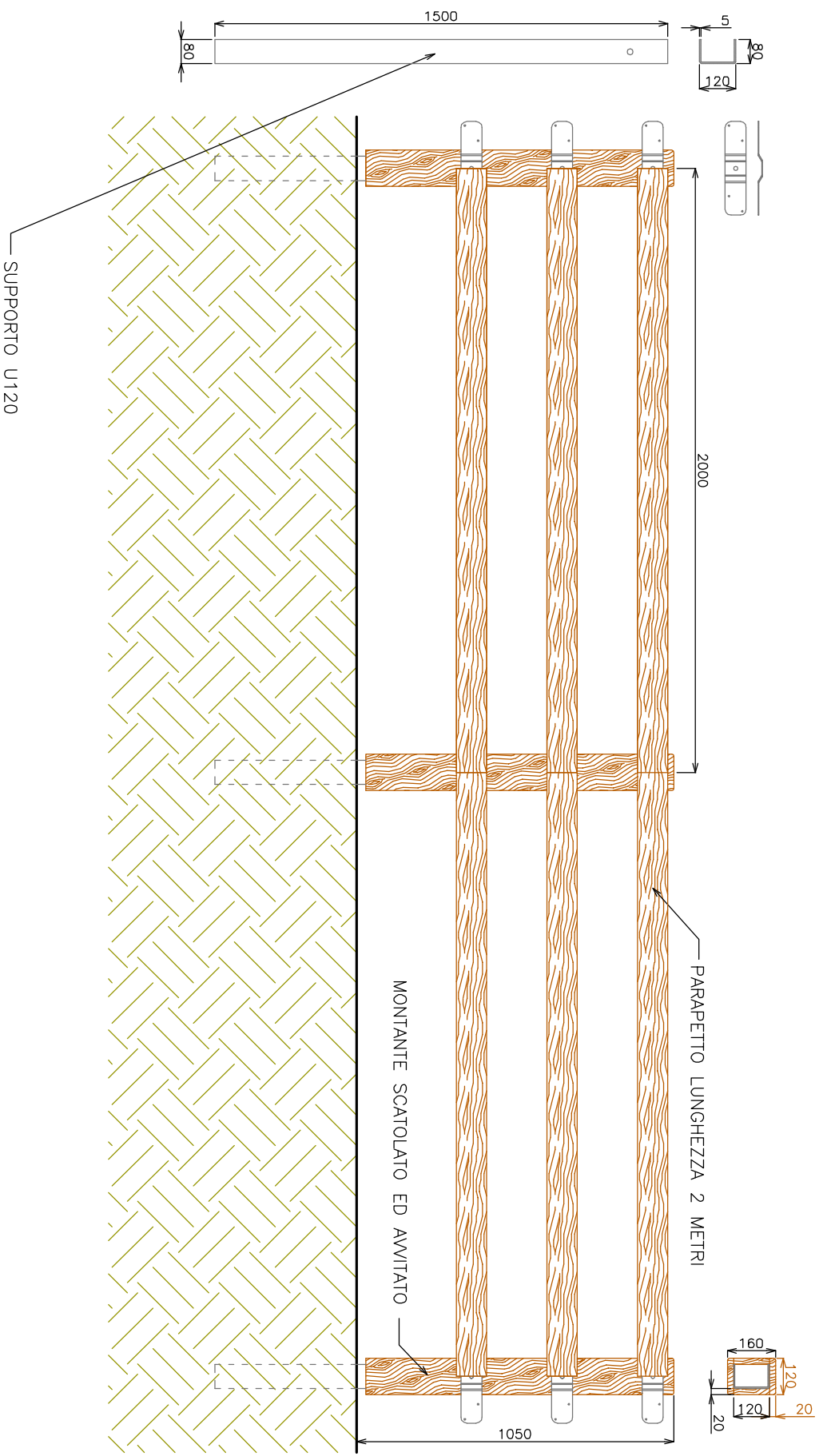

SEZIONE ORIZZONTALE

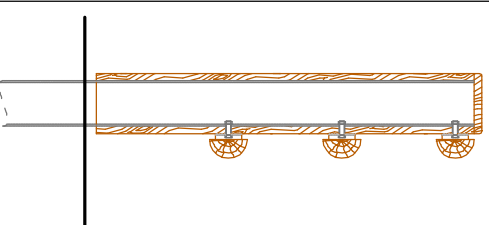

SEZIONE VERTICALE

TRATTI 1-2-4-5-6-7-14-18-25-29

SCALA 1:20

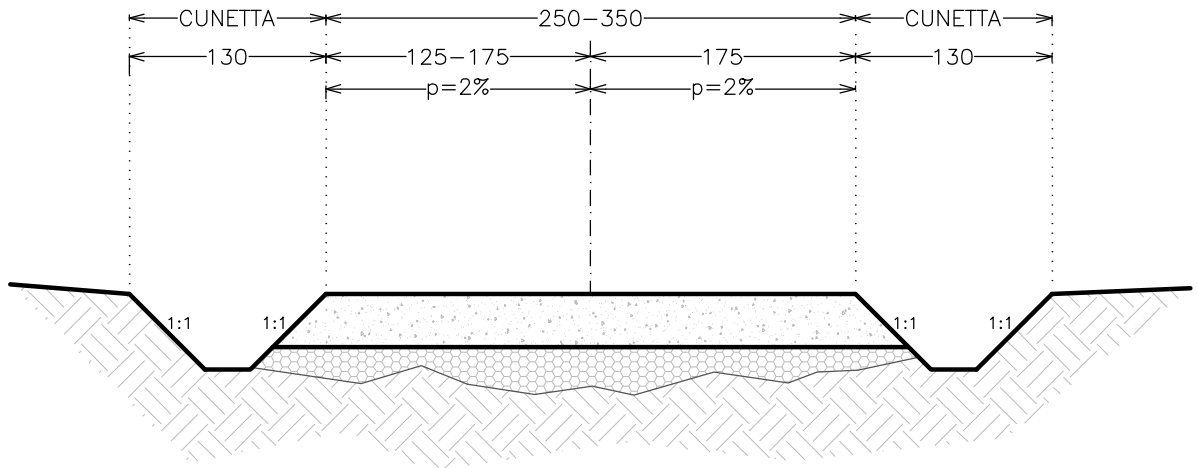

PARTICOLARE SOVRASTRUTTURA

SCALA 1:10

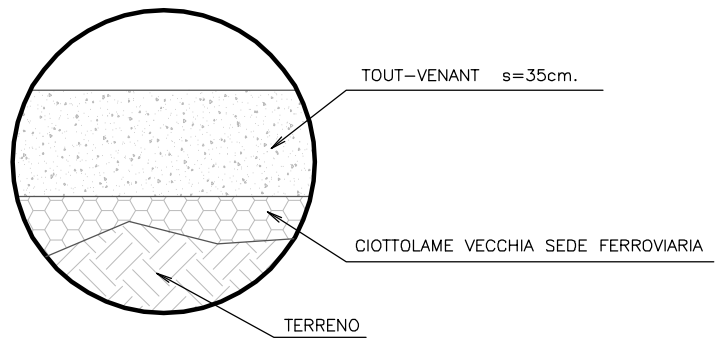

TRATTI 3-8

SCALA 1:20

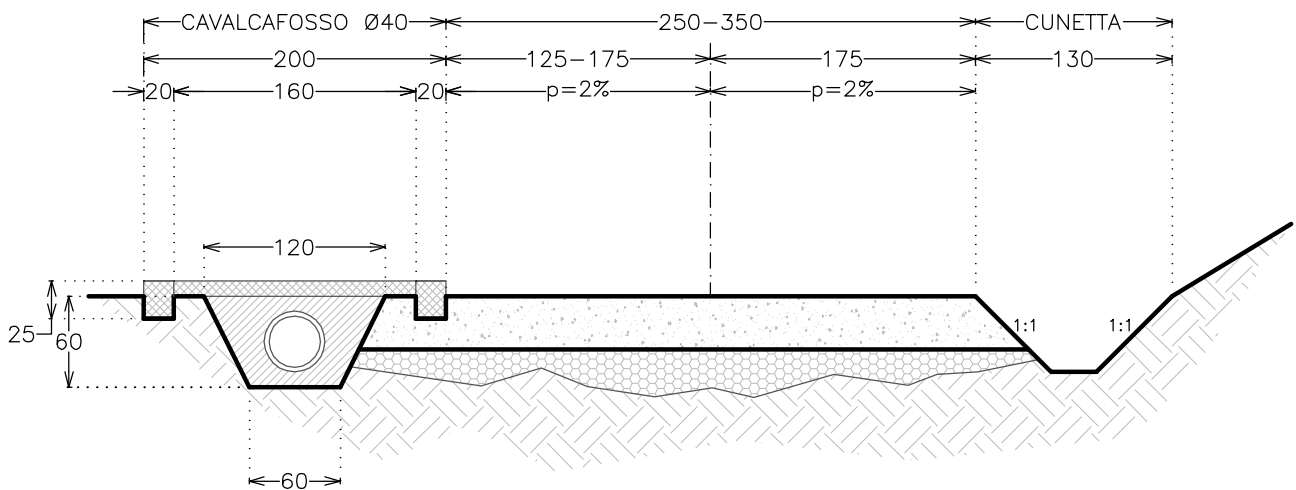

TRATTO 12

SCALA 1:20

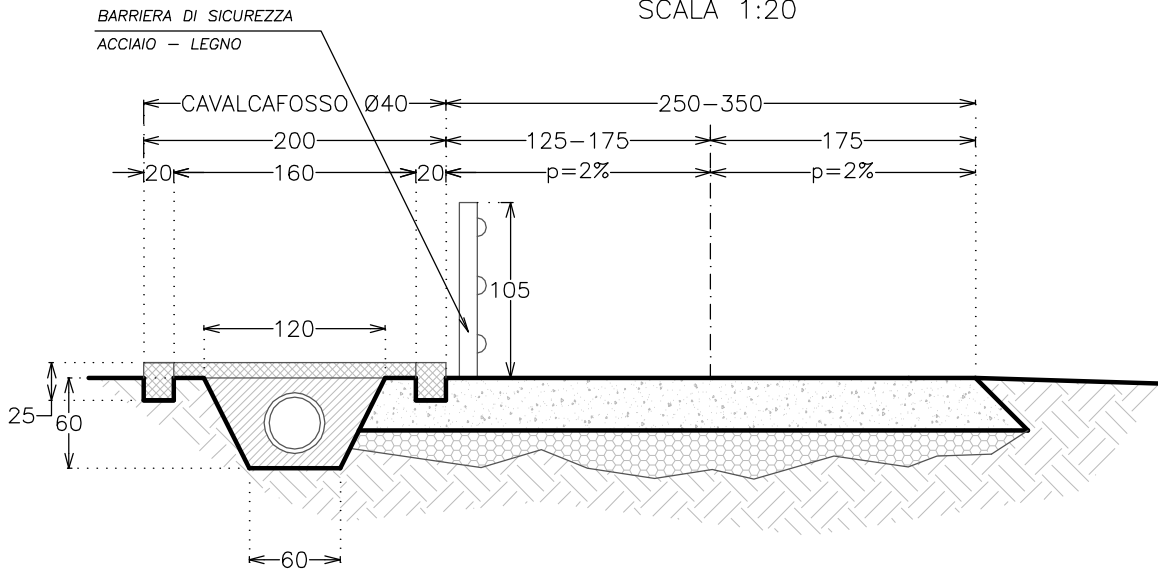

TRATTI 10-11-17-24-30-34

SCALA 1:20

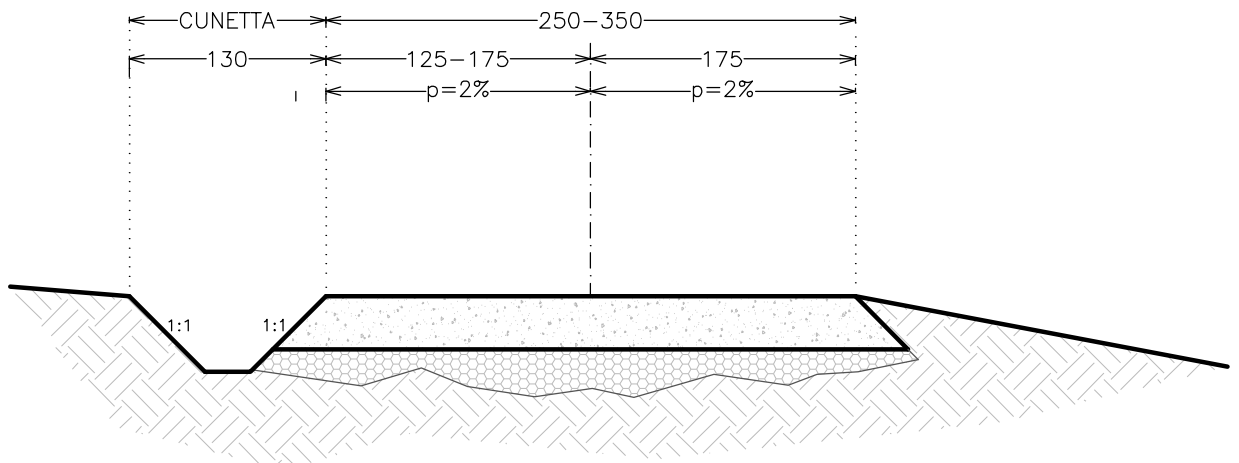

TRATTI 10-11-13-16-21-27-31

SCALA 1:20

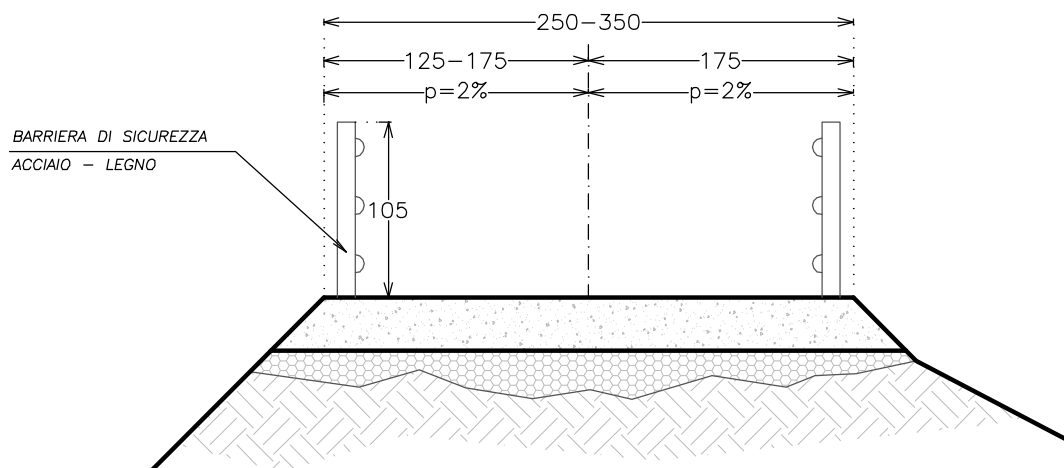

TRATTI 15-35

SCALA 1:20

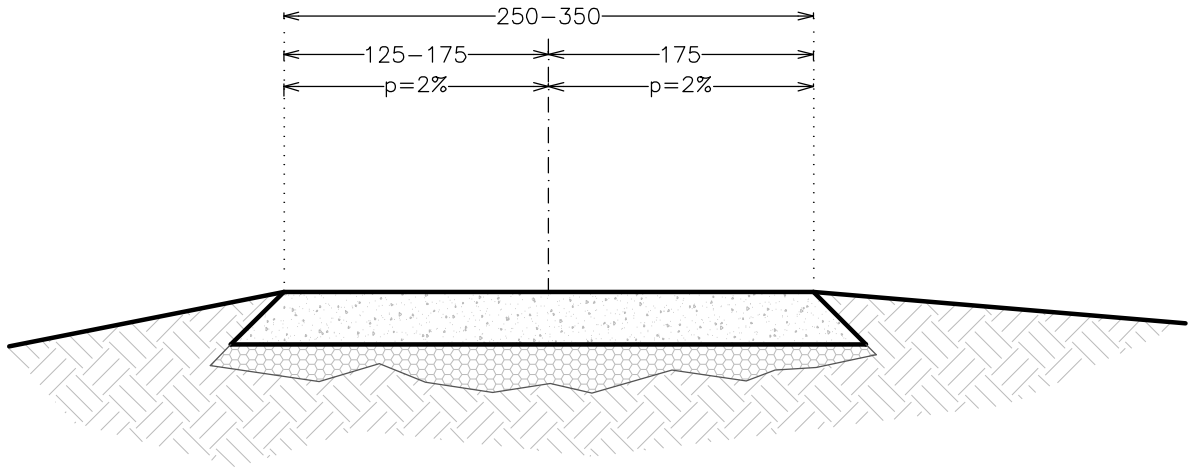

TRATTO 19-22-23-33

SCALA 1:20

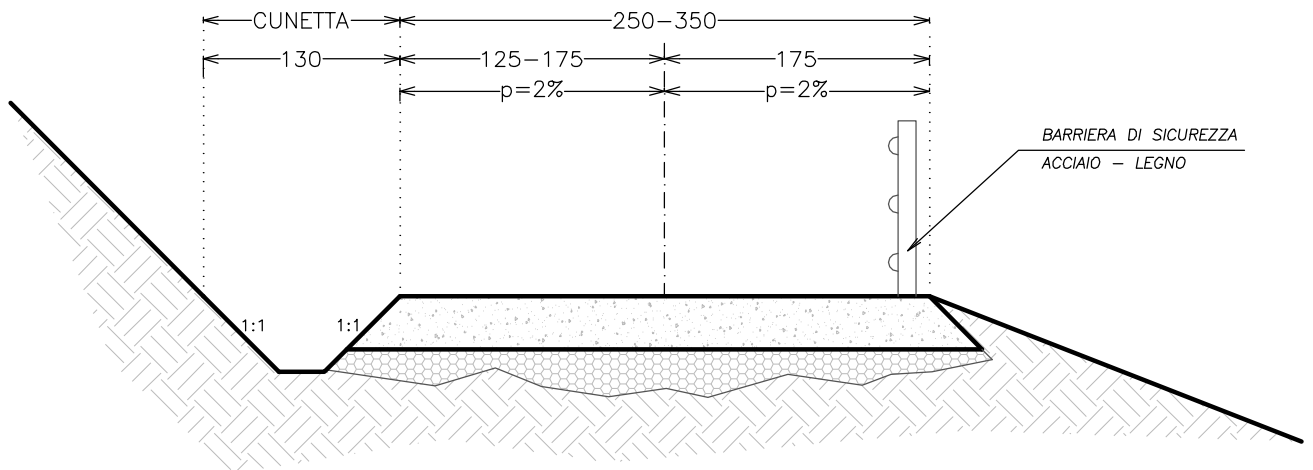

TRATTO 20

SCALA 1:20

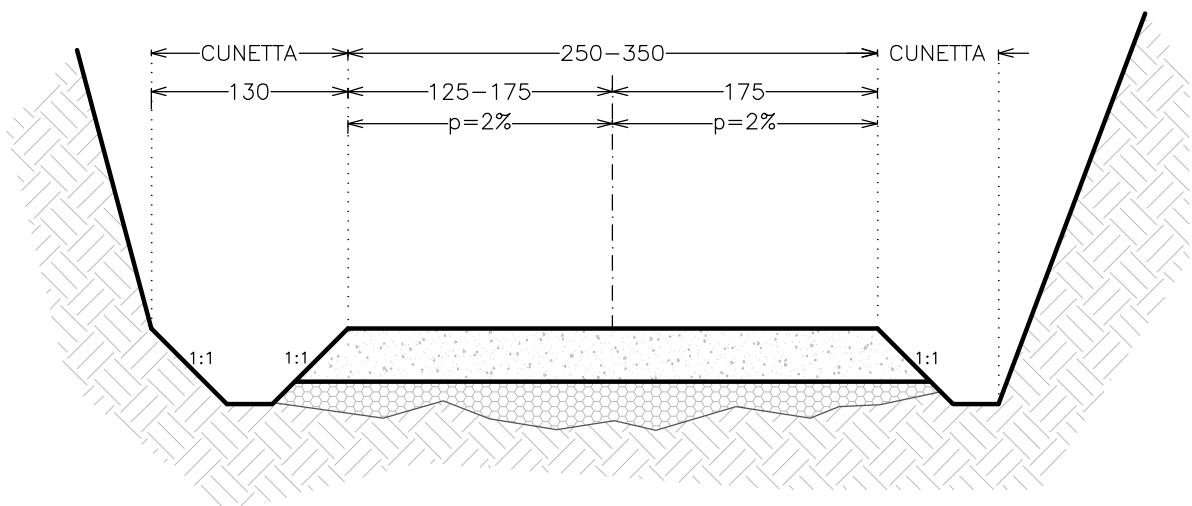

TRATTO 26

SCALA 1:20

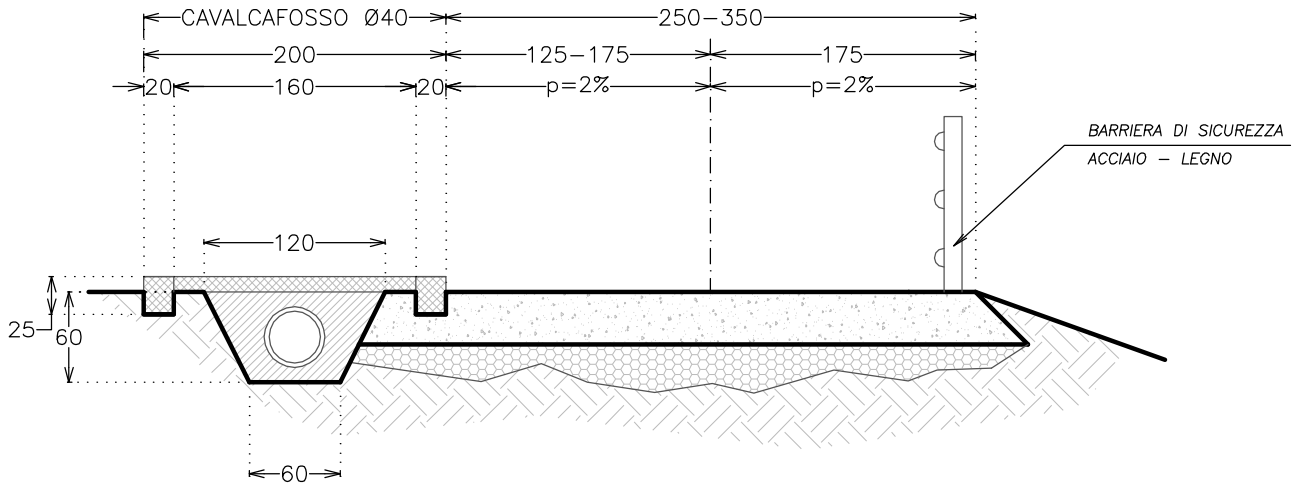

TRATTO 28

SCALA 1:20

